

MONTAGEANLEITUNG

ASSEMBLY INSTRUCTIONS

NOTICE DE MONTAGE

MONTAGEHANDLEIDING

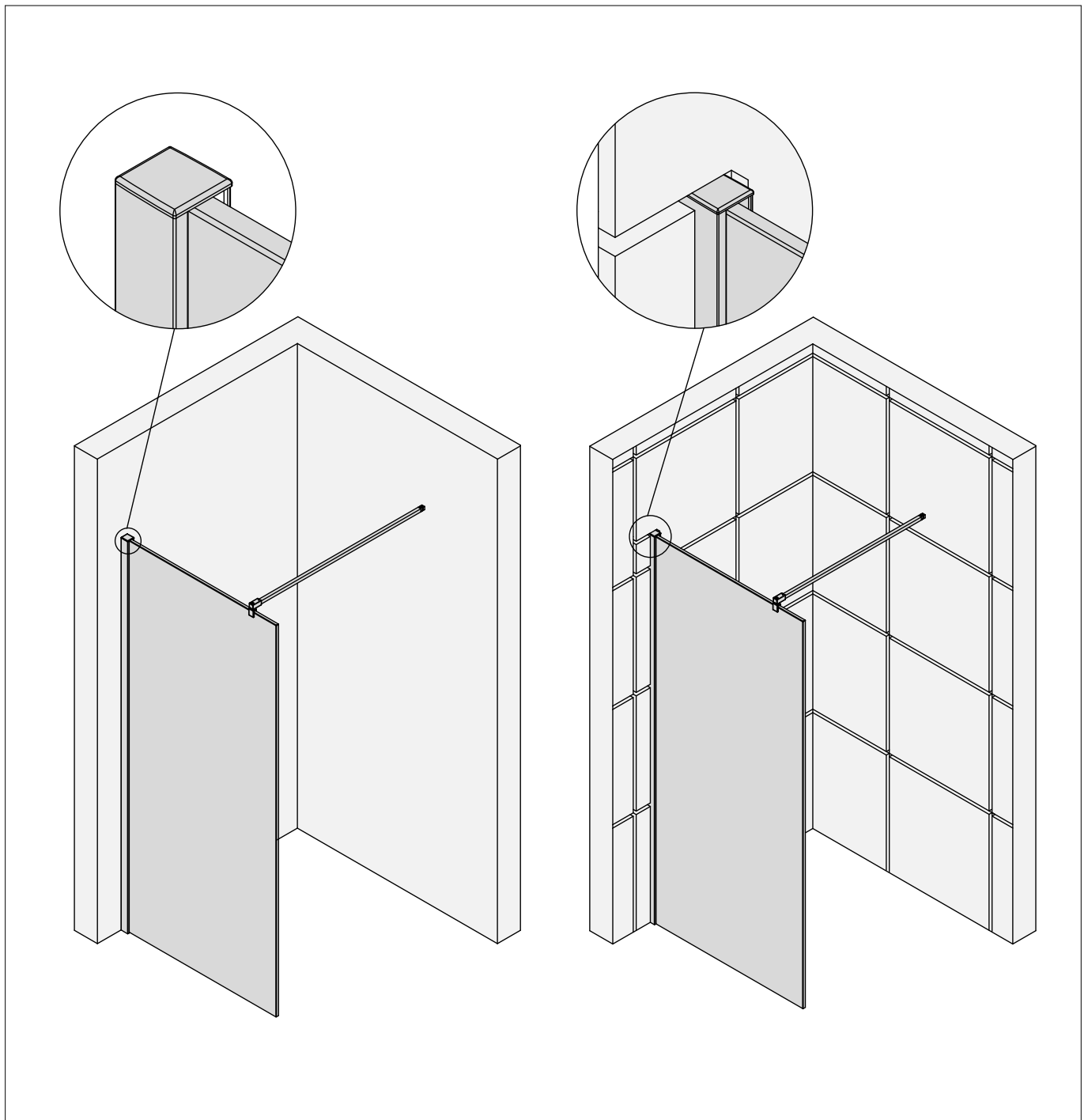



SICHERHEITSHINWEISE / SAFETY INSTRUCTIONS CONSEILS DE SÉCURITÉ / VEILIGHEIDSAANWIJZINGEN



de Glaskanten schützen

en Protect glass edges

fr Protégez les bords du verre

nl Glasranden beschermen

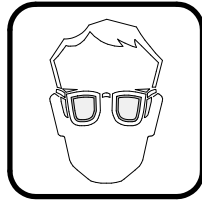

de Schutzbrille tragen

en Wear safety goggles

fr Portez des lunettes de protection

nl Veiligheidsbril dragen

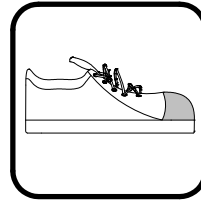

de Sicherheitsschuhe tragen

en Wear safety shoes

fr Portez des chaussures de sécurité

nl Veiligheidsschoenen dragen

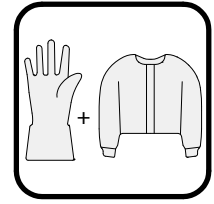

de Lange Handschuhe und langärmelige Kleidung tragen

en Wear long gloves and long-sleeved clothing

fr Portez des gants longs et des vêtements à manches longues

nl Draag lange handschoenen en kleding met lange mouwen

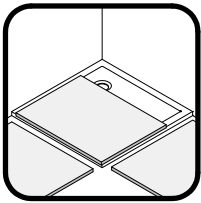

de Decken im Arbeitsbereich und dessen Umfeld auslegen

en Cover the shower tray and its area completely

fr Couvrez complètement le bac de douche et ses environs

nl Dekens op de douchebak en de omgeving leggen

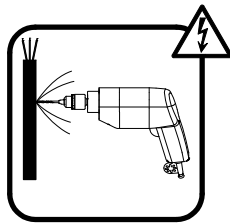

de Über die Lage der Stromleitung informieren

en Get information about the location of the power line

fr Informez-vous sur l'emplacement de la ligne électrique

nl Informeren over de locatie van de hoogspanningslijn

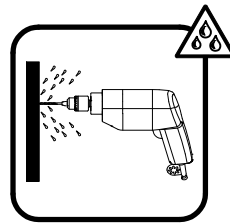

de Über die Lage der Wasserleitung informieren

en Get information about the location of the water pipe

fr Informez-vous sur l'emplacement de la ligne d'eau

nl Informeren over de locatie van de waterleiding

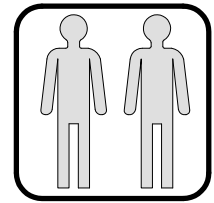

de Empfohlene Montage mit 2 Personen.

en Assembly recommended with 2 persons

fr Montage recommandé avec 2 personnes

nl Aanbevolen montage met 2 personen

HINWEIS / NOTE / NOTE / NOOT

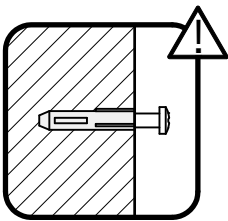

de Vor der Montage die Beschaffenheit des Mauerwerks überprüfen. Gegebenenfalls ist das im Lieferumfang enthaltene Befestigungsmaterial nicht für die Befestigung geeignet.

en Check the condition of the masonry before installation. If applicable, the fixing material included in the scope of delivery is not suitable for mounting.

fr Vérifiez l'état de la maçonnerie avant le montage. Le cas échéant, le matériel d'approvisionnement compris dans la livraison n'est pas adapté à la fixation.

nl Controleer de toestand van het metselwerk voor de installatie. Indien gewenst is het bij de levering inbegrepen bevestigingsmateriaal niet geschikt voor montage.

de Die Aufstellfläche der Duschkabine muss eben sein.

en The installation surface of the shower enclosure must be level.

fr La surface d'installation de la cabine de douche doit être plane.

nl Het montagevlak van de douchewand moet waterpas zijn.

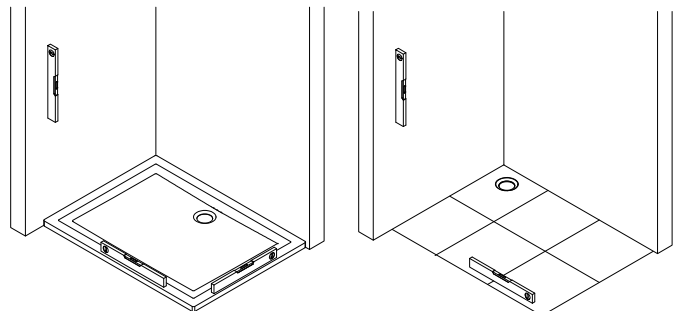

MONTAGEANLEITUNG

ASSEMBLY INSTRUCTIONS

NOTICE DE MONTAGE

MONTAGEHANDLEIDING

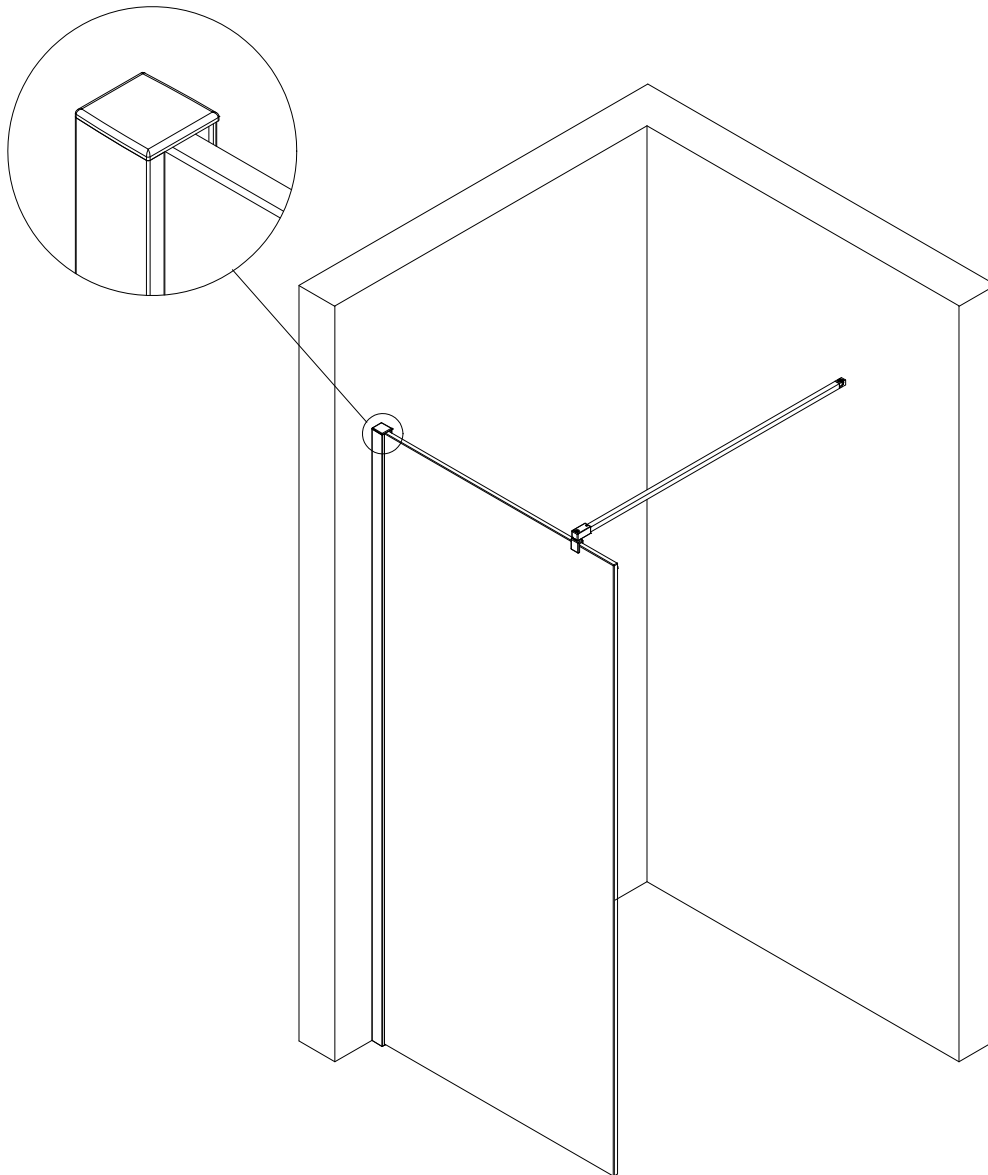

MAßE / DIMENSIONS / DIMENSIONS / AFMETINGEN

- de** Prüfen, ob die gemessenen Maße innerhalb der Tabellenwerte (A, B bzw. C, D) liegen, damit die Duschkabine problemlos, anhand der Montageanleitung aufgebaut werden kann.
- en** Check whether the measured dimensions are within the table values (A, B or C, D), so that the shower enclosure can be assembled without any problems using the assembly instructions.
- fr** Vérifier que les dimensions mesurées se situent dans les valeurs du tableau (A, B ou C, D), afin que la cabine de douche puisse être montée sans problèmes en suivant les instructions de montage.
- nl** Controleer of de gemeten afmetingen binnen de tabelwaarden (A, B of C, D) vallen, zodat de douchewand zonder problemen met behulp van de montagehandleiding kan worden gemonteerd.

de Montage ohne Duschwanne

(Abmessungen des Produktes) (Glasmitte)

en Mounting without shower tray

(Mounting on tile) (Middle of the glass)

fr Montage sans receveur de douche

(Montage sur carrelage) (Dimension mi-verre)

nl Montage zonder douchebak

(Montage op tegel) (midden van het glas)

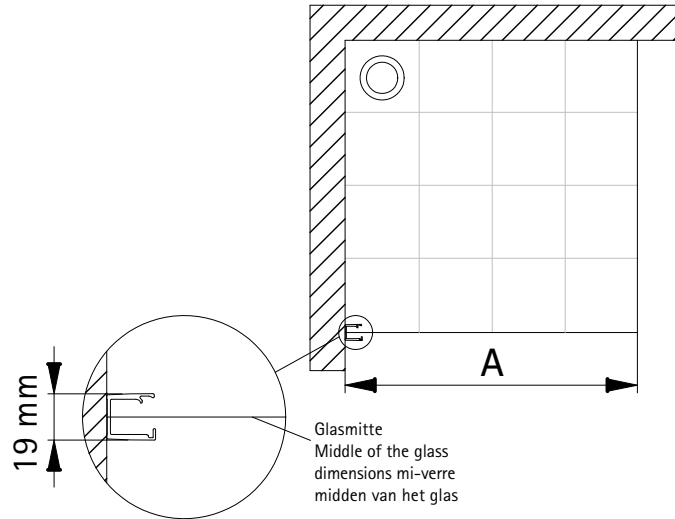

| Version | A |
|---------|----------------|
| 900 mm | 890 - 900 mm |
| 1000 mm | 990 - 1000 mm |
| 1200 mm | 1190 - 1200 mm |
| 1400 mm | 1390 - 1400 mm |
| 1600 mm | 1590 - 1600 mm |
| 1800 mm | 1790 - 1800 mm |

1672-6

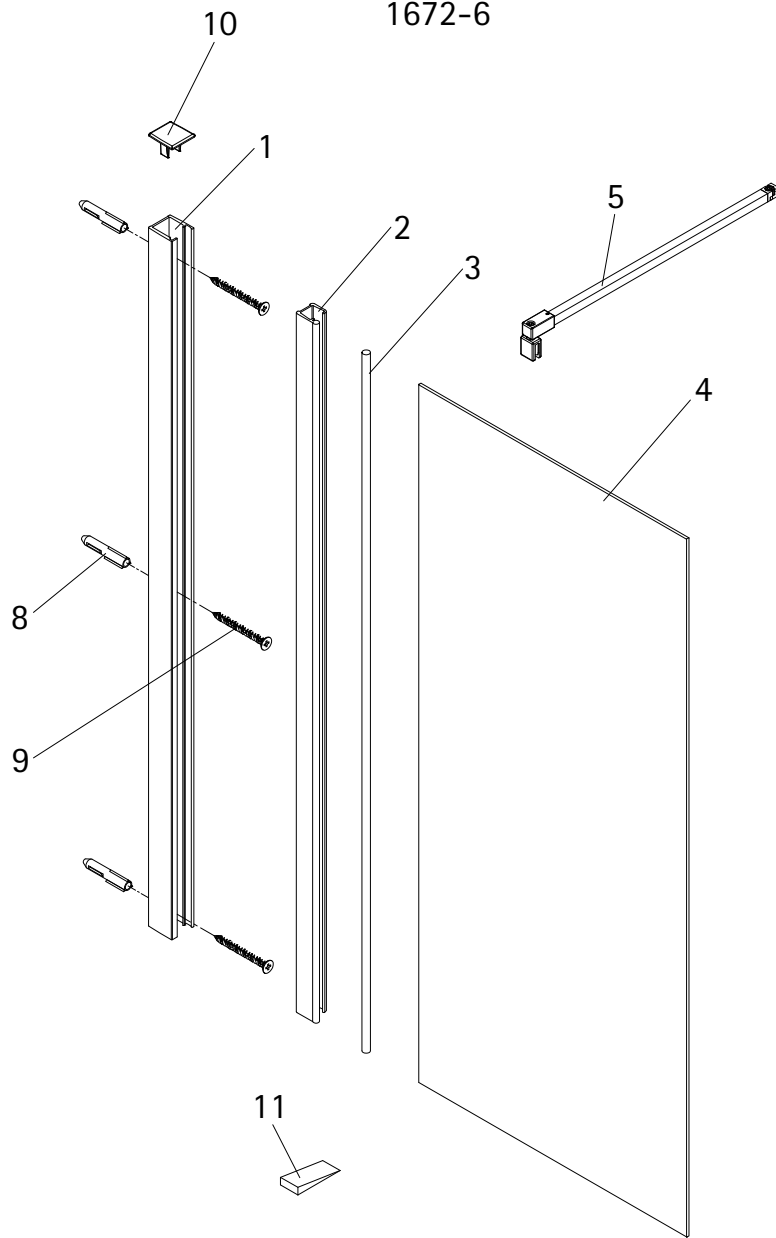

| Pos. | Bezeichnung | Ersatzteil-Nr. | Preis | Pos. | Bezeichnung | Ersatzteil-Nr. | Preis |
|------|---|----------------|----------------|------|---------------------------|----------------|-------------|
| 1# | 1x Wandanschlussprofil | E100242-8 | Stück 156,20 € | 8* | 3x Dübel S6 | | |
| 1# | 1x Wandanschlussprofil (Sonderfarbe) | E100242-8 | Stück 254,00 € | 9* | 3x Schraube 4,2 x 45mm | | |
| 2 | 1x Klemm-Dichtprofil (inkl. Pos. 3) | E100243-8 | Set 57,60 € | 10 | 1x Abdeckkappe | E74205-3 | Set 12,50 € |
| 3 | 1x Silikonschnurdichtung | | | 11 | 1x Silikonkeile (6 Stück) | E100203 | Set 17,80 € |
| 4 | 1x Frontscheibe | | | | | | |
| 5# | 1x Stabilisationsbügel komplett | E100340 | Stück 69,20 € | | * Montagezubehör | E74200-4 | 17,80 € |
| 5# | 1x Stabilisationsbügel komplett (Sonderfarbe) | E100340 | Stück 129,00 € | | # optional | | |

de Geben Sie bei farbigen Ersatzteilen den Farbcode mit an: 41 - chrom | 68 - schwarz | 70 - weiß matt | 90 - Edelstahl | 280 - gun metal | 281 - gold gebürstet | 282 - kupfer gebürstet

en

| Pos. | Description | part no | spare part | price | Pos. | Description | part no | spare part | price |
|------|---------------------------------|-----------|------------|----------|------|------------------------------|----------|------------|---------|
| 1# | 1x wall connection profile | E100242-8 | Stück | 156,20 € | 8* | 3x dowel S6 | | | |
| 1# | 1x wall connection profile | E100242-8 | Stück | 245,00 € | 9* | 3x screw 4,2 x 45 mm | | | |
| 2 | 1x inner sealing (incl. Pos. 3) | E100243-8 | Set | 57,60 € | 10 | 1x cover caps | E74205-3 | Set | 12,50 € |
| 3 | 1x silicone cord sealing | | | | 11 | 1x silicone wedges (6 piece) | E100203 | Set | 17,80 € |
| 4 | 1x frontpanel | | | | | | | | |
| 5# | 1x stabilizing bar | E100340 | Stück | 69,20 € | | * mounting equipment | E74200-4 | | 17,80 € |
| 5# | 1x stabilizing bar | E100340 | Stück | 129,00 € | | # optional | | | |

en

Please state the colour code for coloured spare parts: 41 - chrome | 68 - black | 70 white | 90 - stainless steel | 280 - gunmetal | 281 - brushed gold | 282 - brushed copper

fr

| Pos. | Description | N° pièce détachée | prix | Pos. | Description | N° pièce détachée | prix |
|------|--|-------------------|-------|----------|-------------|--------------------------------|----------|
| 1# | 1x profilé mural de fixation | E100242-8 | Stück | 156,20 € | 8* | 3x cheville S6 | |
| 1# | 1x profilé mural de fixation | E100242-8 | Stück | 254,00 € | 9* | 3x vis 4,2 x 45 mm | |
| 2 | 1x profilé de pincement (pos. 3 incluse) | E100243-8 | Set | 57,60 € | 10 | 1x cache | E74205-3 |
| 3 | 1x joint de cordon en silicone | | | | 11 | 1x cale de silicone (6 unités) | E100203 |
| 4 | 1x paroi frontale | | | | | | |
| 5# | 1x barre de stabilisation | E100340 | Stück | 69,20 € | | * accessoires de montage | E74200-4 |
| 5# | 1x barre de stabilisation | E100340 | Stück | 129,00 € | | # en option | |

fr

Veuillez indiquer le code couleur pour les pièces de rechange colorées : 41 - chromé | 68 - noir | 70 - blanc | 90 - acier inoxydable | 280 - gunmetal | 281 - or brossé | 282 - cuivre brossé

nl

| Pos. | Omschrijving | Onderdeel nr. | Prijs | Pos. | Omschrijving | Onderdeel nr. | Prijs |
|------|--|---------------|-------|----------|--------------|-----------------------------|----------|
| 1# | 1x wandaanluitprofiel | E100242-8 | Stück | 156,20 € | 8* | 3x plug S6 | |
| 1# | 1x wandaanluitprofiel | E100242-8 | Stück | 254,00 € | 9* | 3x schroef 4,2 x 45 mm | |
| 2 | 1x Dichtstrip binnenzijde (incl. Pos. 3) | E100243-8 | Set | 57,60 € | 10 | 1x afdekkapjes | E74205-3 |
| 3 | 1x siliconen koordafdichting | | | | 11 | 1x silicone keggen (6 stuk) | E100203 |
| 4 | 1x frontpanel | | | | | | |
| 5# | 1x stabilisatie stang | E100340 | Stück | 69,20 € | | * montageonderdelen | E74200-4 |
| 5# | 1x stabilisatie stang | E100340 | Stück | 129,00 € | | # optioneel | |

nl

Gelieve de kleurcode voor gekleurde onderdelen te vermelden: 41 - chroom | 68 - zwart | 70 - wit | 90 - roestvrij staal | 280 - gunmetal | 281 - brushed gold | 282 - brushed copper

BENÖTIGTES WERKZEUG / TOOL NEEDED
OUTILLAGE NECESSAIRE / BENODIGD WERKTWIG

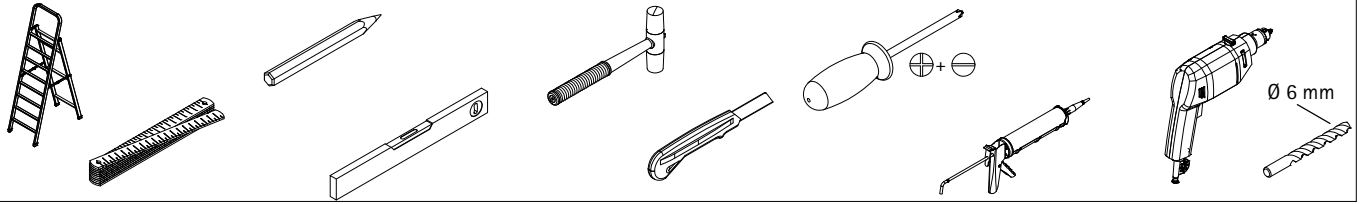

MONTAGE / ASSEMBLY / ASSEMBLAGE / ASSEMBLAGE

1

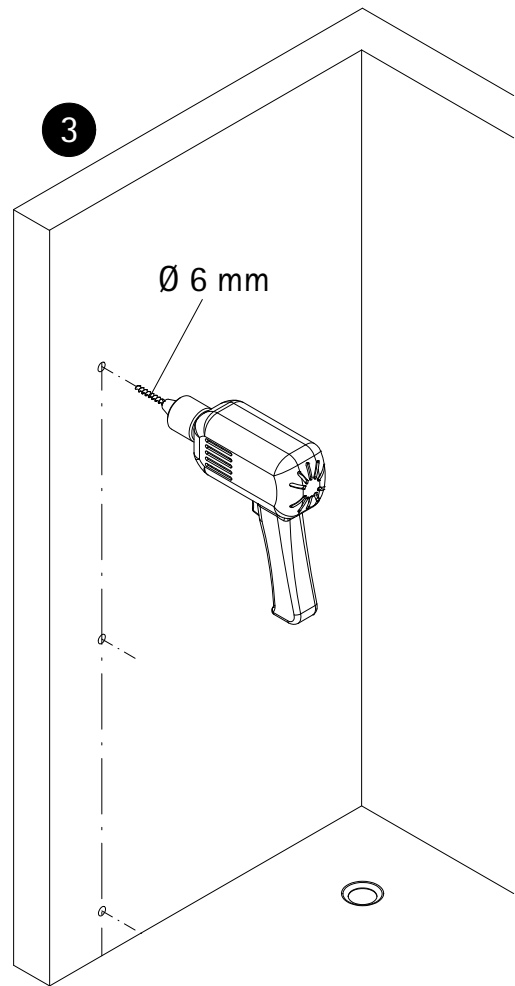
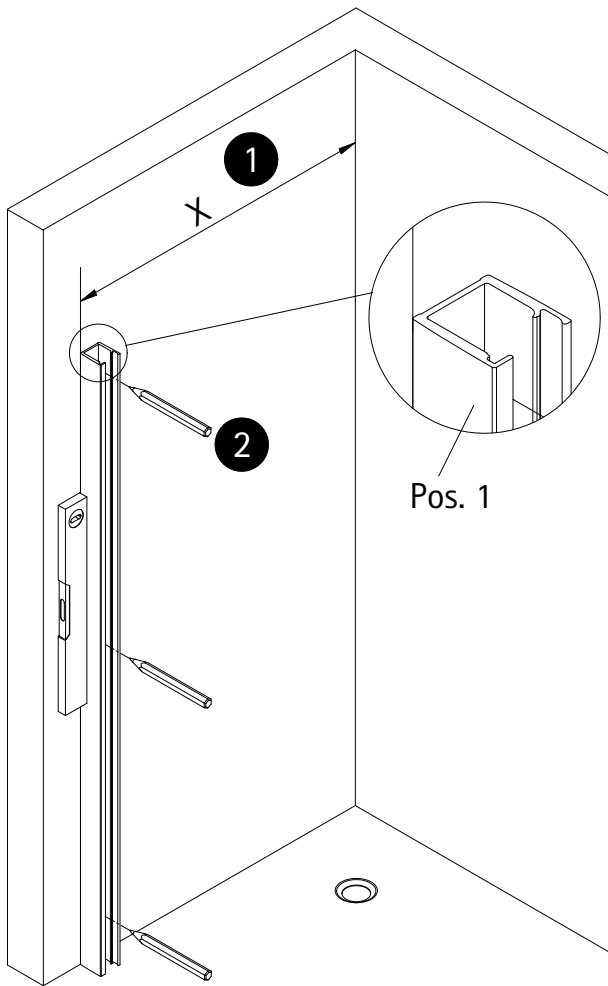

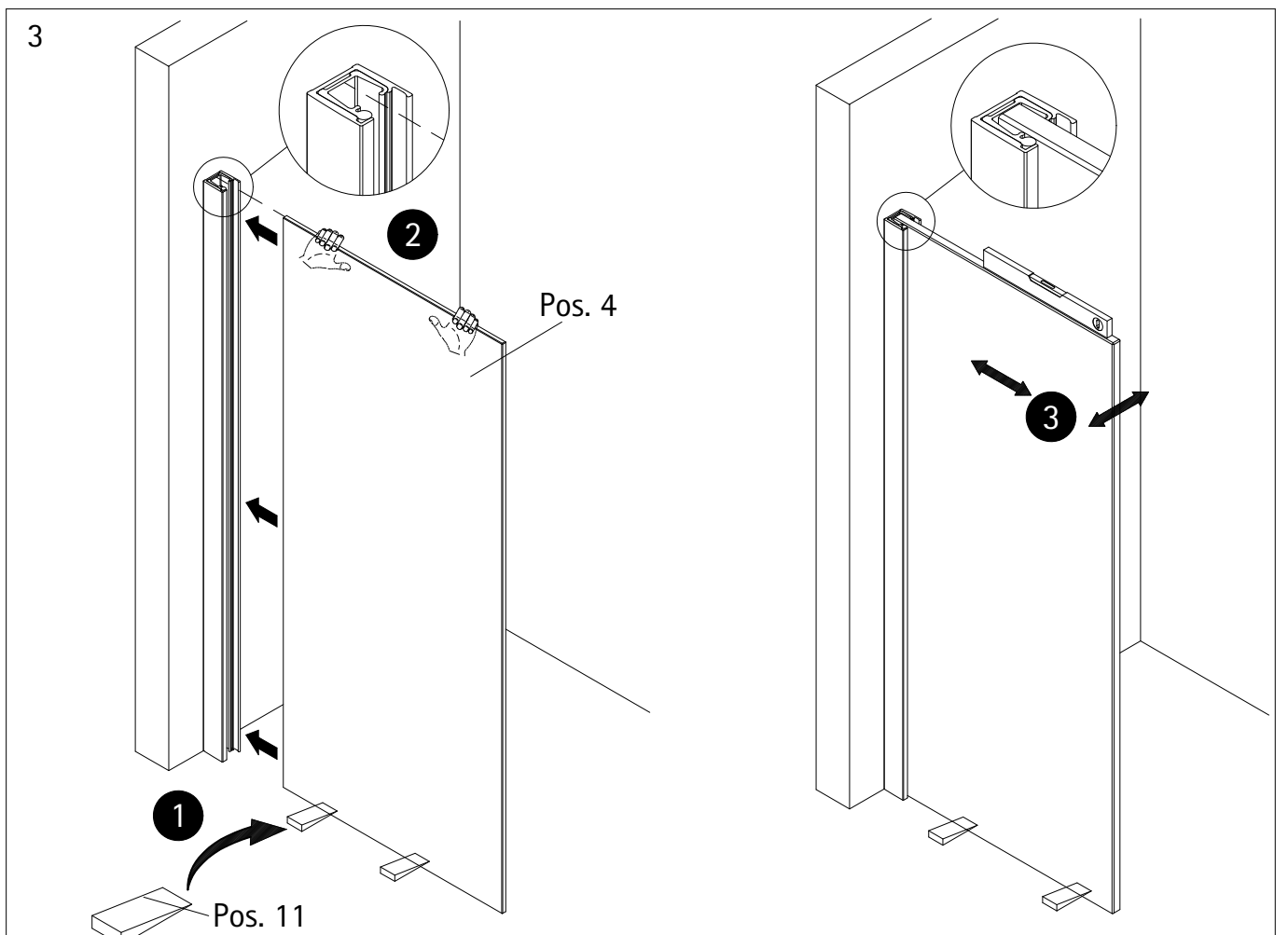
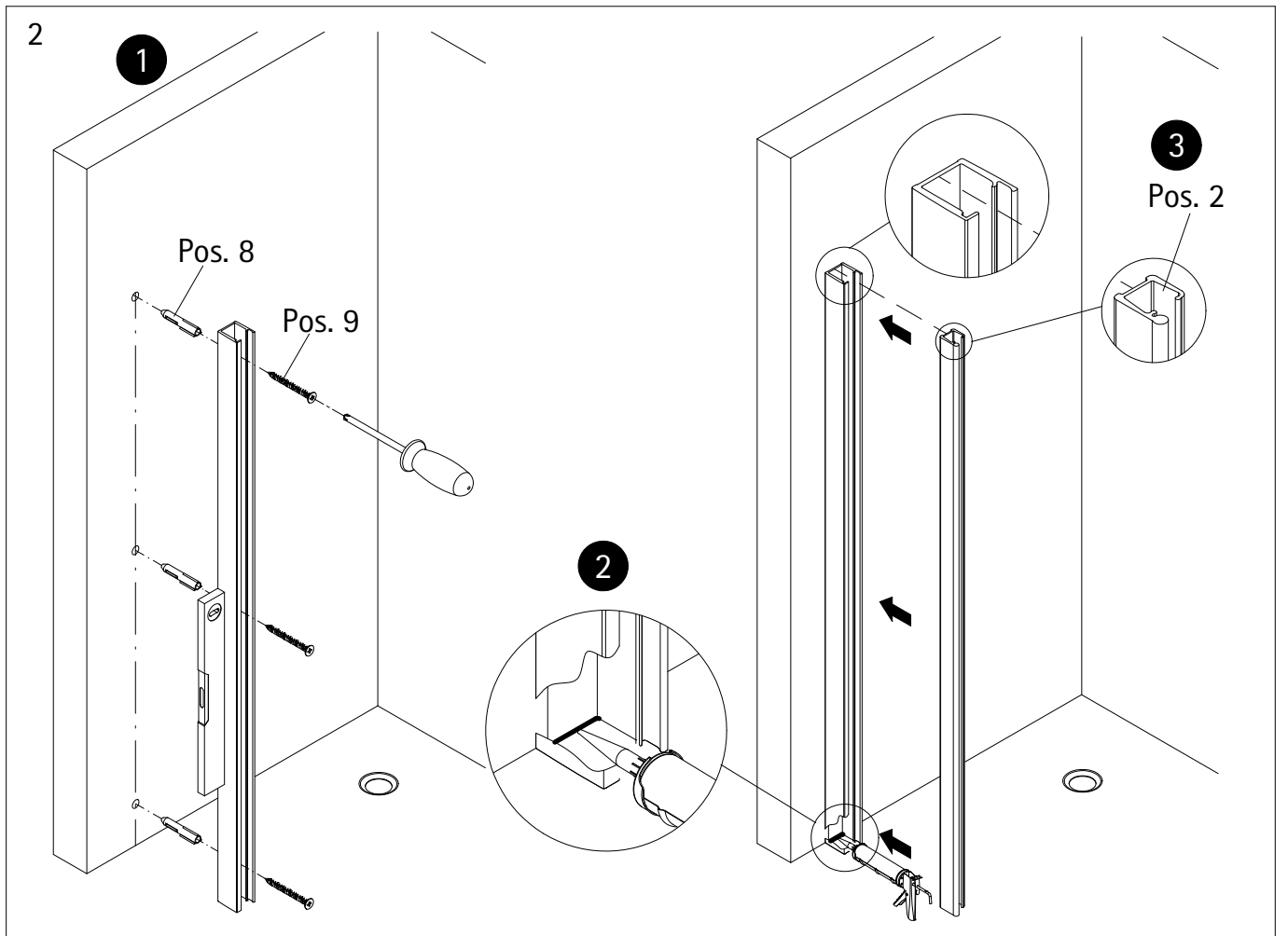

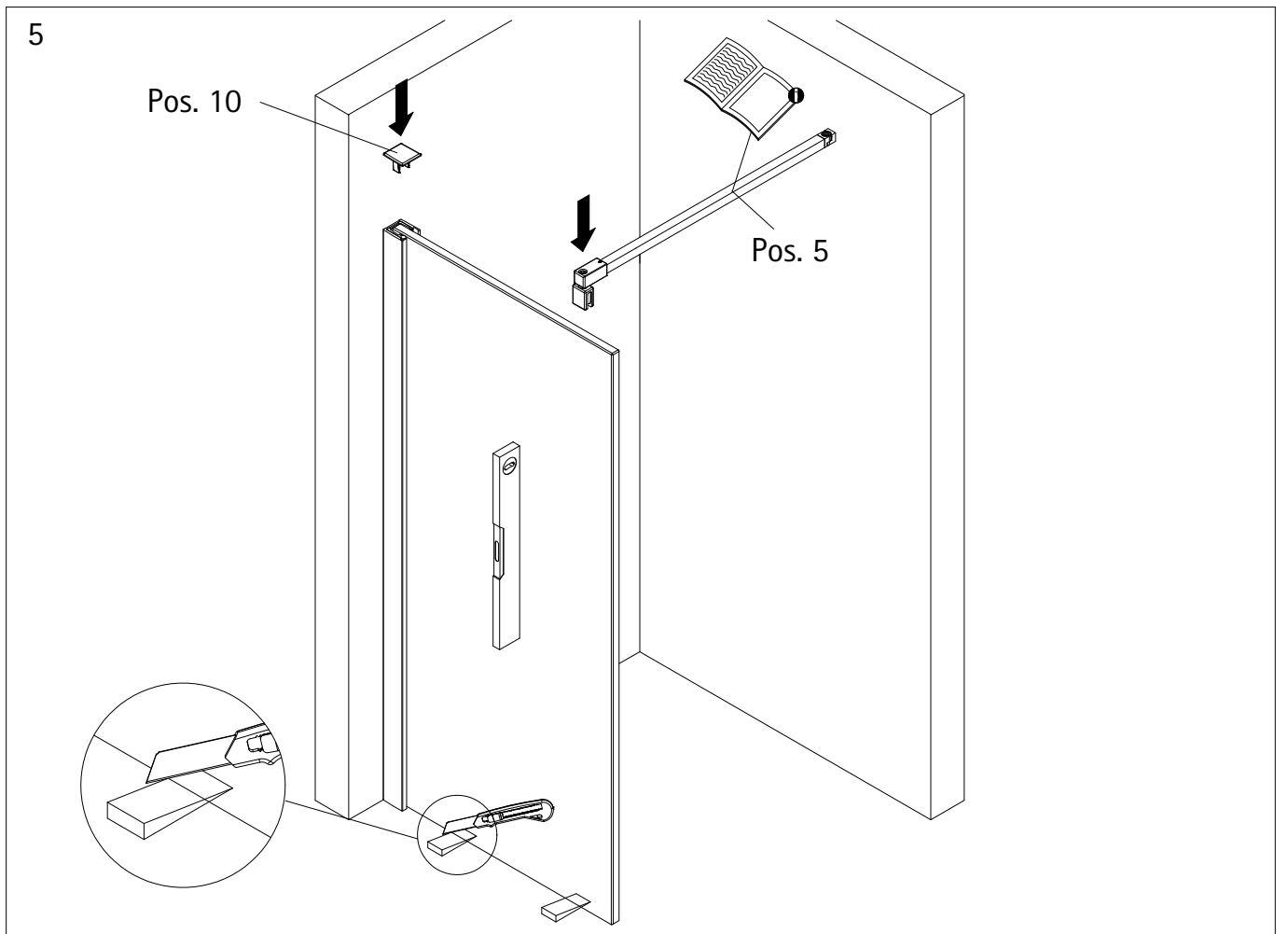
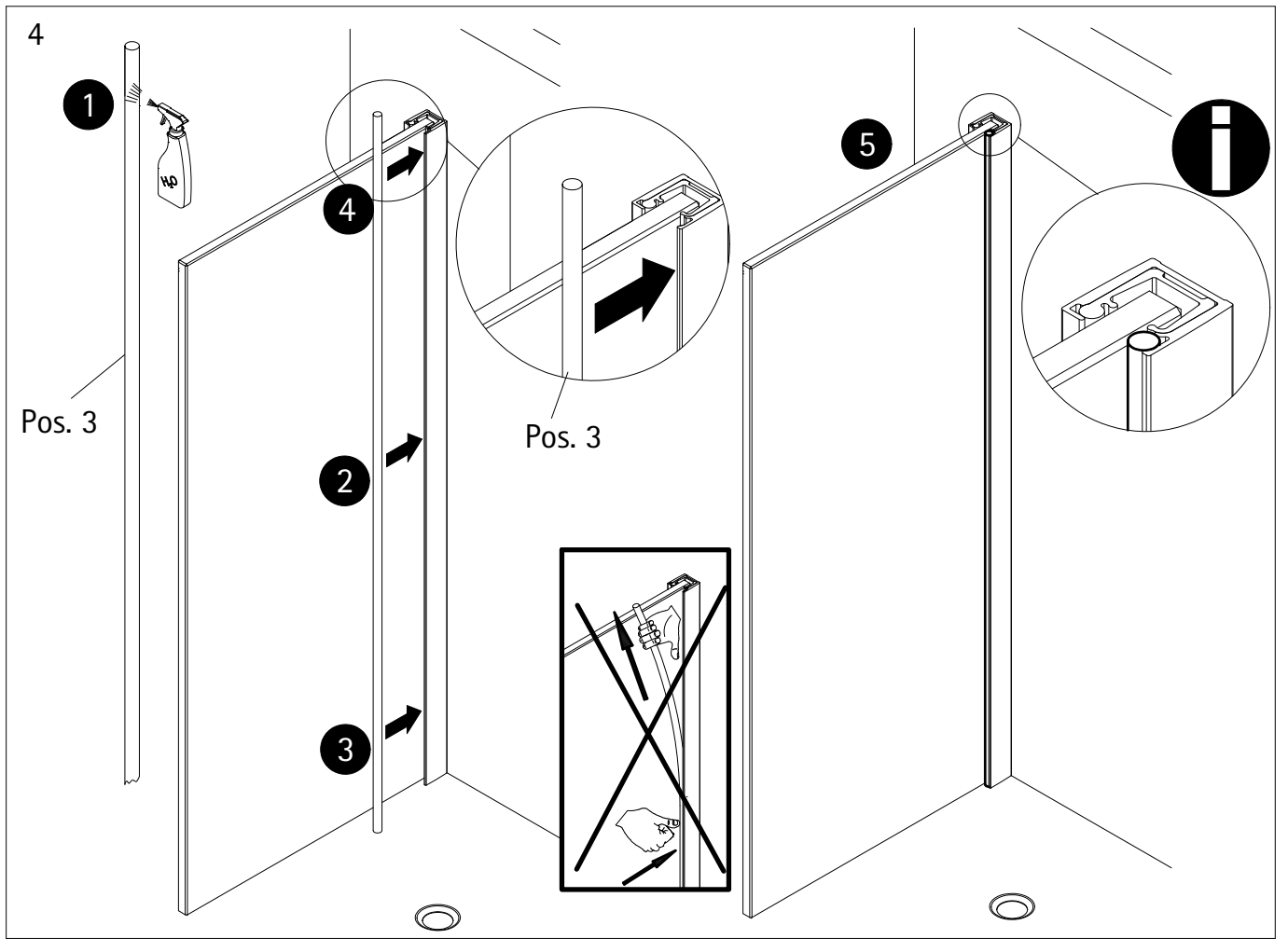

6

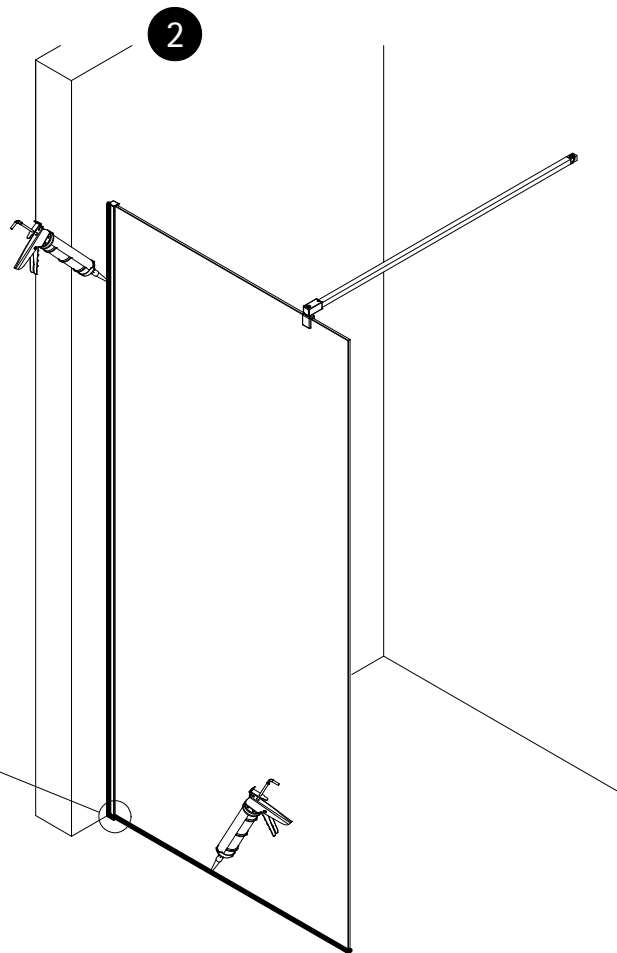
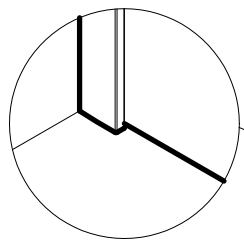
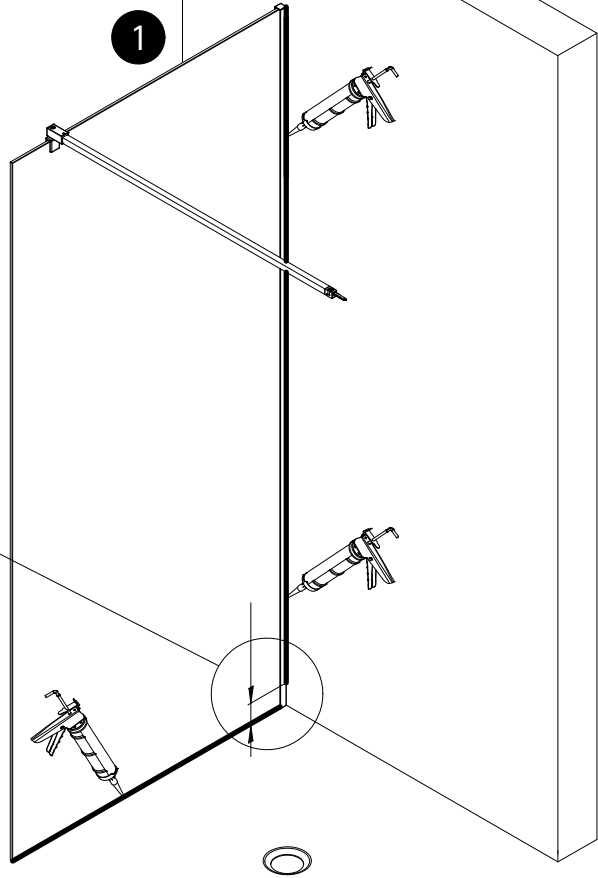
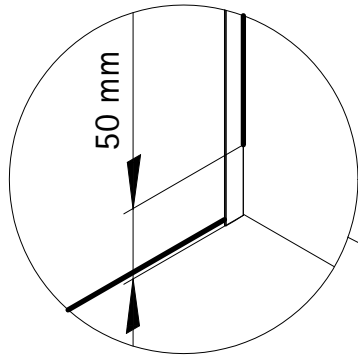

24 h

MONTAGEANLEITUNG

ASSEMBLY INSTRUCTIONS

NOTICE DE MONTAGE

MONTAGEHANDLEIDING

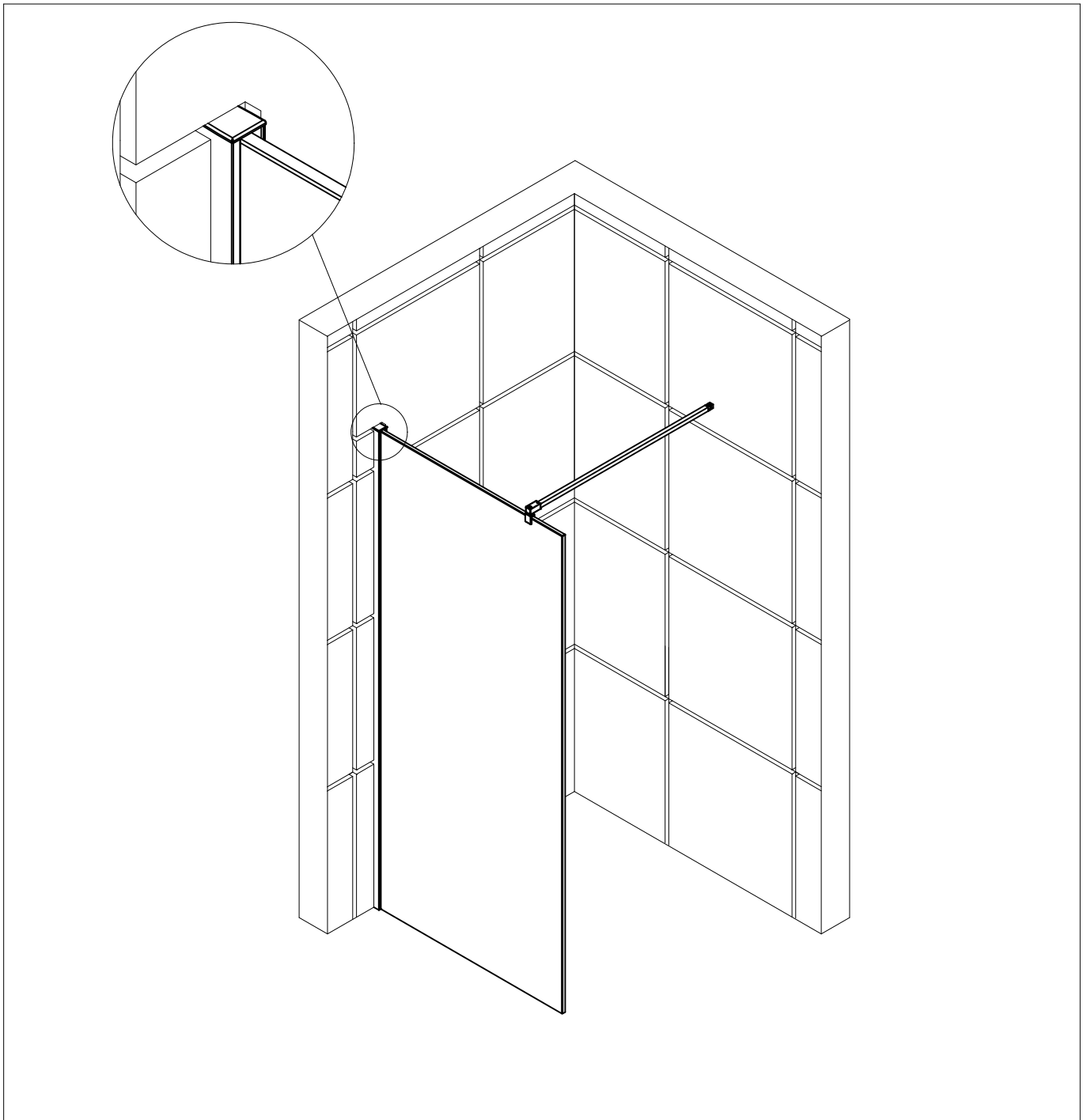

MAßE / DIMENSIONS / DIMENSIONS / AFMETINGEN

- de** Prüfen, ob die gemessenen Maße innerhalb der Tabellenwerte (A, B bzw. C, D) liegen, damit die Duschkabine problemlos, anhand der Montageanleitung aufgebaut werden kann.
- en** Check whether the measured dimensions are within the table values (A, B or C, D), so that the shower enclosure can be assembled without any problems using the assembly instructions.
- fr** Vérifier que les dimensions mesurées se situent dans les valeurs du tableau (A, B ou C, D), afin que la cabine de douche puisse être montée sans problèmes en suivant les instructions de montage.
- nl** Controleer of de gemeten afmetingen binnen de tabelwaarden (A, B of C, D) vallen, zodat de douchewand zonder problemen met behulp van de montagehandleiding kan worden gemonteerd.

de Montage ohne Duschwanne

(Abmessungen des Produktes) (Glasmitte)

en Mounting without shower tray

(Mounting on tile) (Middle of the glass)

fr Montage sans receveur de douche

(Montage sur carrelage) (Dimension mi-verre)

nl Montage zonder douchebak

(Montage op tegel) (midden van het glas)

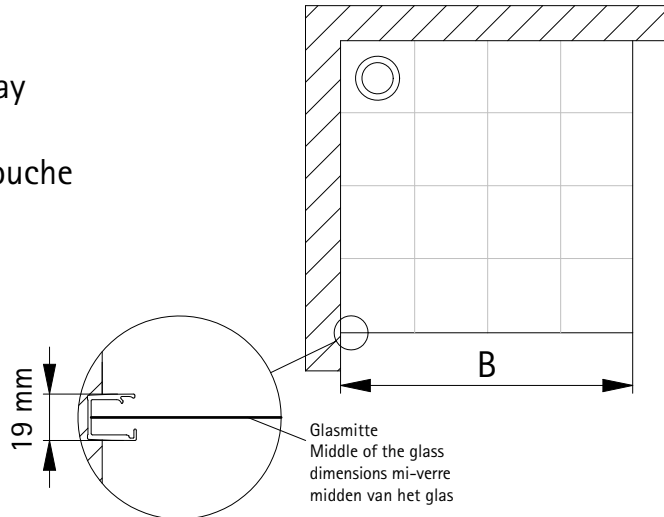

| Version | A |
|---------|----------------|
| 900 mm | 875 - 885 mm |
| 1000 mm | 975 - 985 mm |
| 1200 mm | 1175 - 1185 mm |
| 1400 mm | 1375 - 1385 mm |
| 1600 mm | 1575 - 1585 mm |
| 1800 mm | 1775 - 1785 mm |

1672-6

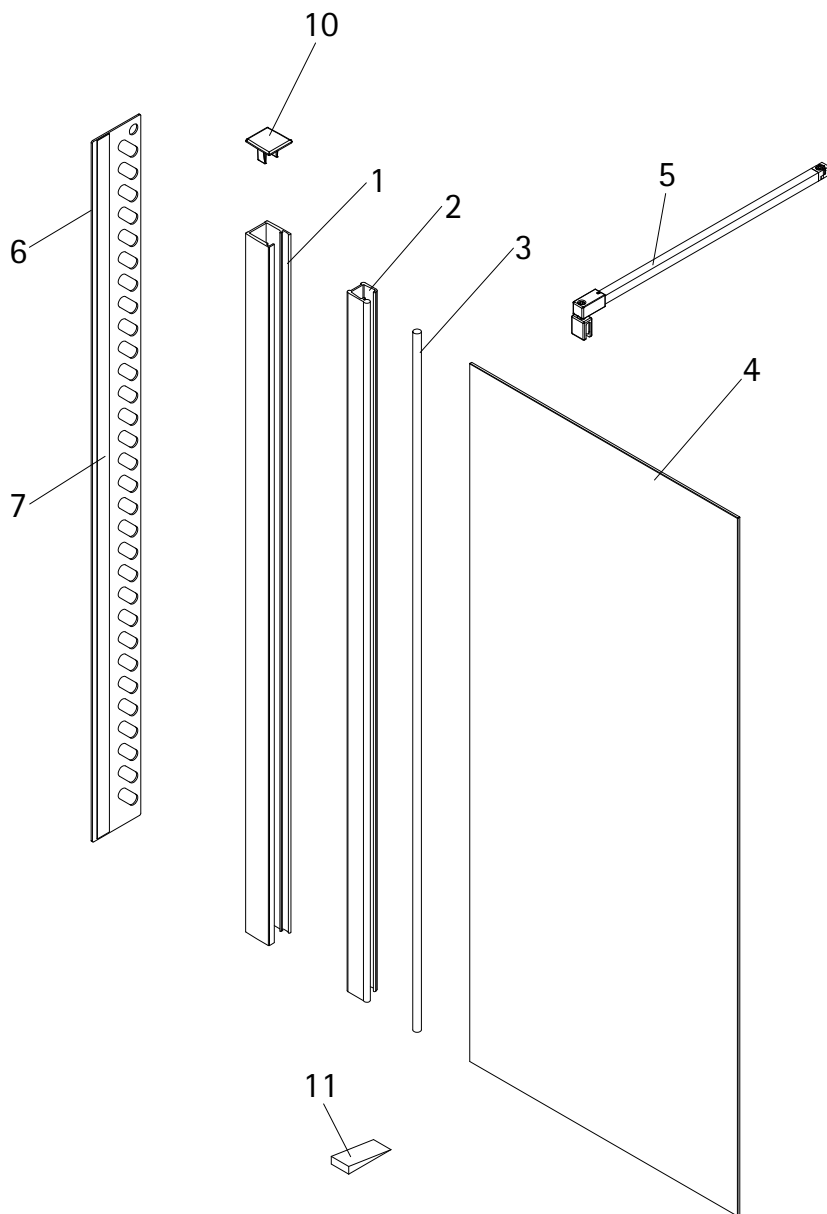

| Pos. | Bezeichnung | Ersatzteil-Nr. | Preis | Pos. | Bezeichnung | Ersatzteil-Nr. | Preis |
|------|---|----------------|----------------|------|--|----------------|---------------|
| 1# | 1x Wandanschlussprofil | E100242-8 | Stück 156,20 € | 6 | 1x Unterputz-Montageschiene (inkl. Pos. 7) | E100241 | Stück 48,20 € |
| 1# | 1x Wandanschlussprofil (Sonderfarbe) | E100242-8 | Stück 254,00 € | 7 | 1x Doppelseitiges Klebeband | | |
| 2 | 1x Klemm-Dichtprofil (inkl. Pos. 3) | E100243-8 | Set 57,60 € | 10 | 1x Abdeckkappe | E74205-3 | Set 12,50 € |
| 3 | 1x Silikonschnurdichtung | | | 11 | 1x Silikonkeile (6 Stück) | E100203 | Set 17,80 € |
| 4 | 1x Frontscheibe | | | | | | |
| 5# | 1x Stabilisationsbügel komplett | E100340 | Stück 69,20 € | | * Montagezubehör | E74200-4 | 17,80 € |
| 5# | 1x Stabilisationsbügel komplett (Sonderfarbe) | E100340 | Stück 129,00 € | | # optional | | |

de Geben Sie bei farbigen Ersatzteilen den Farbcode mit an: 41 - chrom | 68 - schwarz | 70 - weiß matt | 90 - Edelstahl | 280 - gunmetal | 281 - gold gebürstet | 282 - kupfer gebürstet

en

| Pos. | Description | part no | spare part | price | Pos. | Description | part no | spare part | price |
|------|---------------------------------|-----------|------------|----------|------|--|----------|------------|---------|
| 1# | 1x wall connection profile | E100242-8 | Stück | 156,20 € | 6 | 1x built-in mounting rail (incl. Pos. 7) | E100241 | Stück | 48,20 € |
| 1# | 1x wall connection profile | E100242-8 | Stück | 254,00 € | 7 | 1x double-sided adhesive tape | | | |
| 2 | 1x inner sealing (incl. Pos. 3) | E100243-8 | Set | 57,60 € | 10 | 1x cover caps | E74205-3 | Set | 12,50 € |
| 3 | 1x silicone cord sealing | | | | 11 | 1x silicone wedges (6 piece) | E100203 | Set | 17,80 € |
| 4 | 1x frontpanel | | | | | * mounting equipment | E74200-4 | | 17,80 € |
| 5# | 1x stabilizing bar | E100340 | Stück | 69,20 € | | # optional | | | |
| 5# | 1x stabilizing bar | E100340 | Stück | 129,00 € | | | | | |

Please state the colour code for coloured spare parts: 41 - chrome | 68 - black | 70 white | 90 - stainless steel | 280 - gunmetal | 281 - brushed gold | 282 - brushed copper

fr

| Pos. | Description | N° pièce détachée | prix | Pos. | Description | N° pièce détachée | prix | | |
|------|--|-------------------|-------|----------|-------------|--|----------|-------|---------|
| 1# | 1x profilé mural de fixation | E100242-8 | Stück | 156,20 € | 6 | 1x rail de montage encastré (pos. 7 incluse) | E100241 | Stück | 48,20 € |
| 1# | 1x profilé mural de fixation | E100242-8 | Stück | 254,00 € | 7 | 1x ruban adhésif double face | | | |
| 2 | 1x profilé de pincement (pos. 3 incluse) | E100243-8 | Set | 57,60 € | 10 | 1x cache | E74205-3 | Set | 12,50 € |
| 3 | 1x joint de cordon en silicone | | | | 11 | 1x cale de silicone (6 unités) | E100203 | Set | 17,80 € |
| 4 | 1x paroi frontale | | | | | * accessoires de montage | E74200-4 | | 17,80 € |
| 5# | 1x barre de stabilisation | E100340 | Stück | 69,20 € | | # en option | | | |
| 5# | 1x barre de stabilisation | E100340 | Stück | 129,00 € | | | | | |

Veuillez indiquer le code couleur pour les pièces de rechange colorées : 41 - chrome | 68 - noir | 70 - blanc | 90 - acier inoxydable | 280 - gunmetal | 281 - or brossé | 282 - cuivre brossé

nl

| Pos. | Omschrijving | Onderdeel nr. | Prijs | Pos. | Omschrijving | Onderdeel nr. | Prijs | | |
|------|--|---------------|-------|----------|--------------|--------------------------------------|----------|-------|---------|
| 1# | 1x wandaansluitprofiel | E100242-8 | Stück | 156,20 € | 6 | 1x Inbouw montagerail (incl. Pos. 7) | E100241 | Stück | 48,20 € |
| 1# | 1x wandaansluitprofiel | E100242-8 | Stück | 254,00 € | 7 | 1x tweezijdig plakband | | | |
| 2 | 1x Dichtstrip binnenzijde (incl. Pos. 3) | E100243-8 | Set | 57,60 € | 10 | 1x afdekkapjes | E74205-3 | Set | 12,50 € |
| 3 | 1x siliconen koordafdichting | | | | 11 | 1x silicone keggen (6 stuk) | E100203 | Set | 17,80 € |
| 4 | 1x frontpanel | | | | | * montageonderdelen | E74200-4 | | 17,80 € |
| 5# | 1x stabilisatie stang | E100340 | Stück | 69,20 € | | # optioneel | | | |
| 5# | 1x stabilisatie stang | E100340 | Stück | 129,00 € | | | | | |

Gelieve de kleurcode voor gekleurde onderdelen te vermelden: 41 - chroom | 68 - zwart | 70 - wit | 90 - roestvrij staal | 280 - gunmetal | 281 - brushed gold | 282 - brushed copper

BENÖTIGTES WERKZEUG / TOOL NEEDED
 QUILAGE NECESSAIRE / BENODIGD GEREEDSCHAP

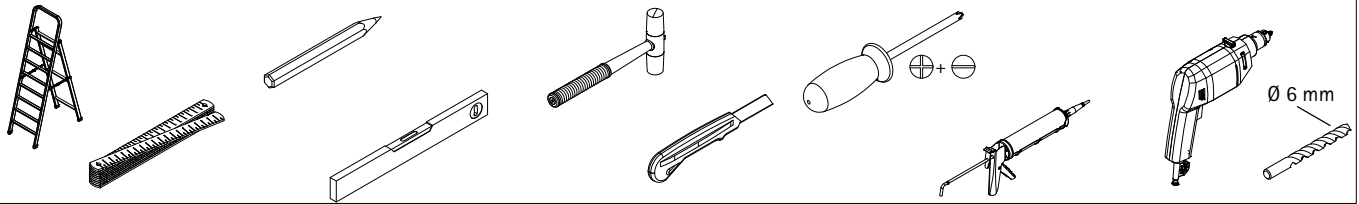

MONTAGE / ASSEMBLY / ASSEMBLÉE / ASSEMBLAGE

1

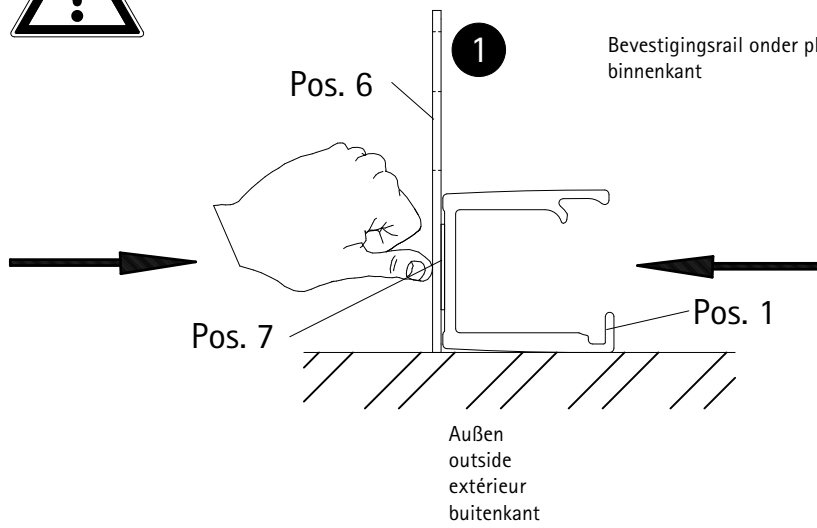

Unterputz-Montageschiene
 innen
 Concealed fastening bar inside
 Barre de fixation encastré intérieur
 Bevestigingsrail onder pleisterlaag,
 binnenkant

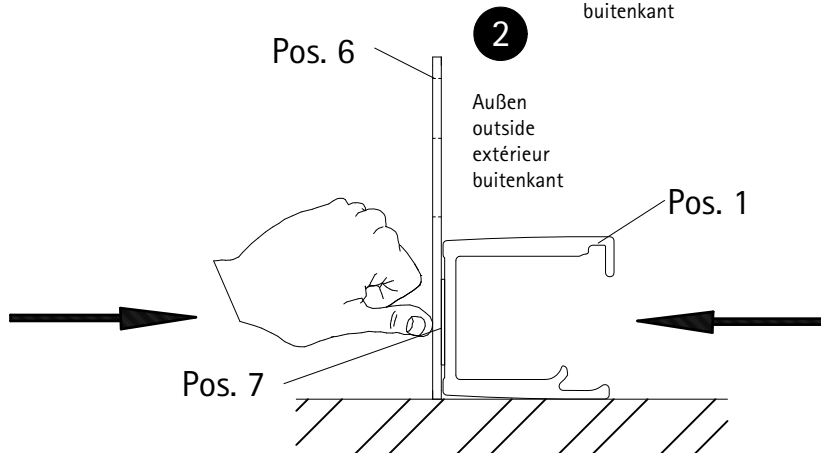
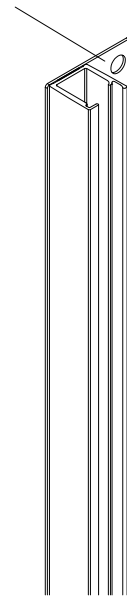

Unterputz-Montageschiene
 außen
 Concealed fastening bar outside
 Barre de fixation encastré extérieur
 Bevestigingsrail onder pleisterlaag,
 buitenkant

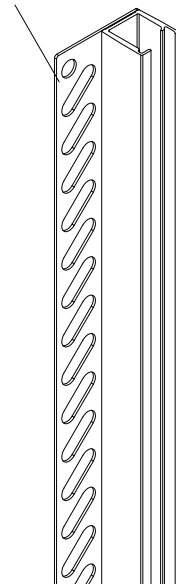

2

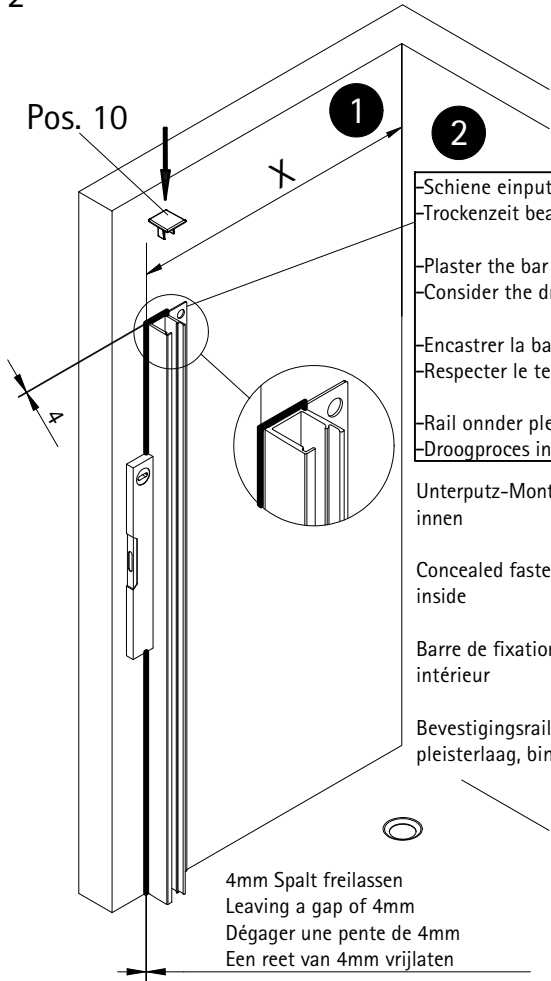

- Schiene einputzen
-Trockenzeit beachten!
- Plaster the bar
-Consider the drying time!
- Encastrer la barre
-Respecter le temps de séchage!
- Rail onder pleister inbouwen
-Droogproces in acht nemen!

Unterputz-Montageschiene innen
Concealed fastening bar inside
Barre de fixation encastré intérieur
Bevestigingsrail onder pleisterlaag, binnenkant

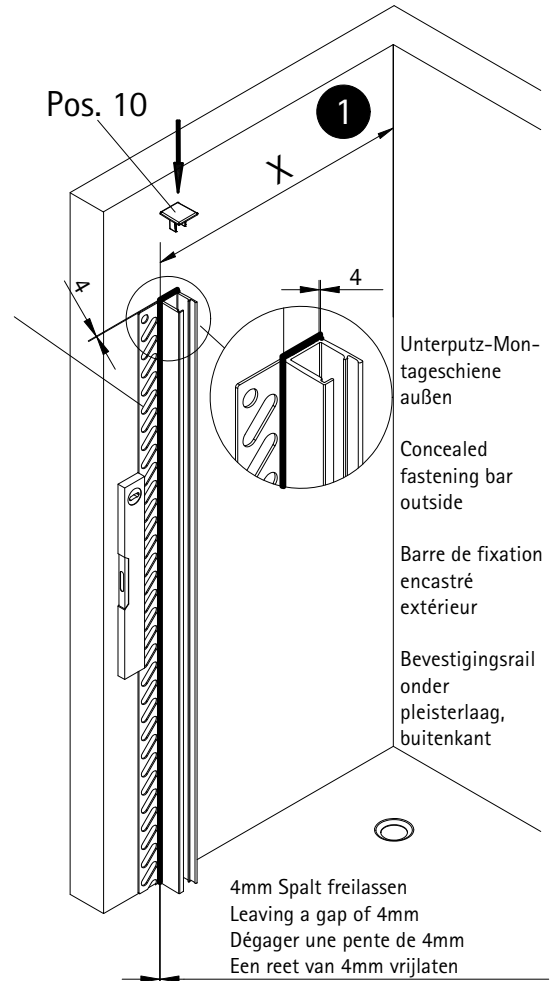

Unterputz-Montageschiene außen
Concealed fastening bar outside
Barre de fixation encastré extérieur
Bevestigingsrail onder pleisterlaag, buitenkant

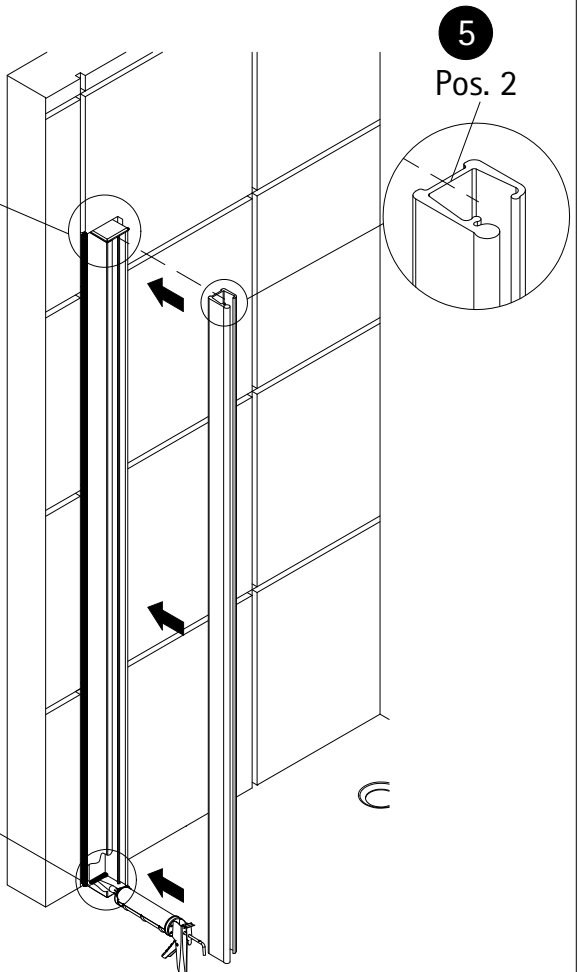
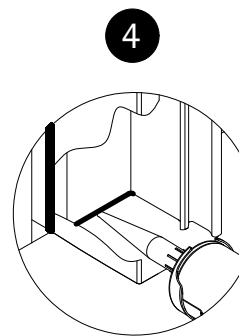
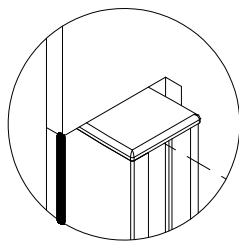
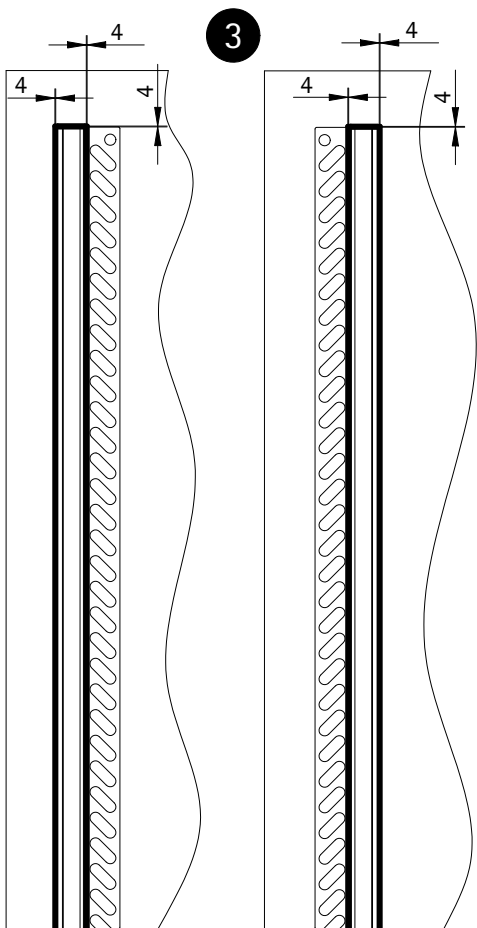

3

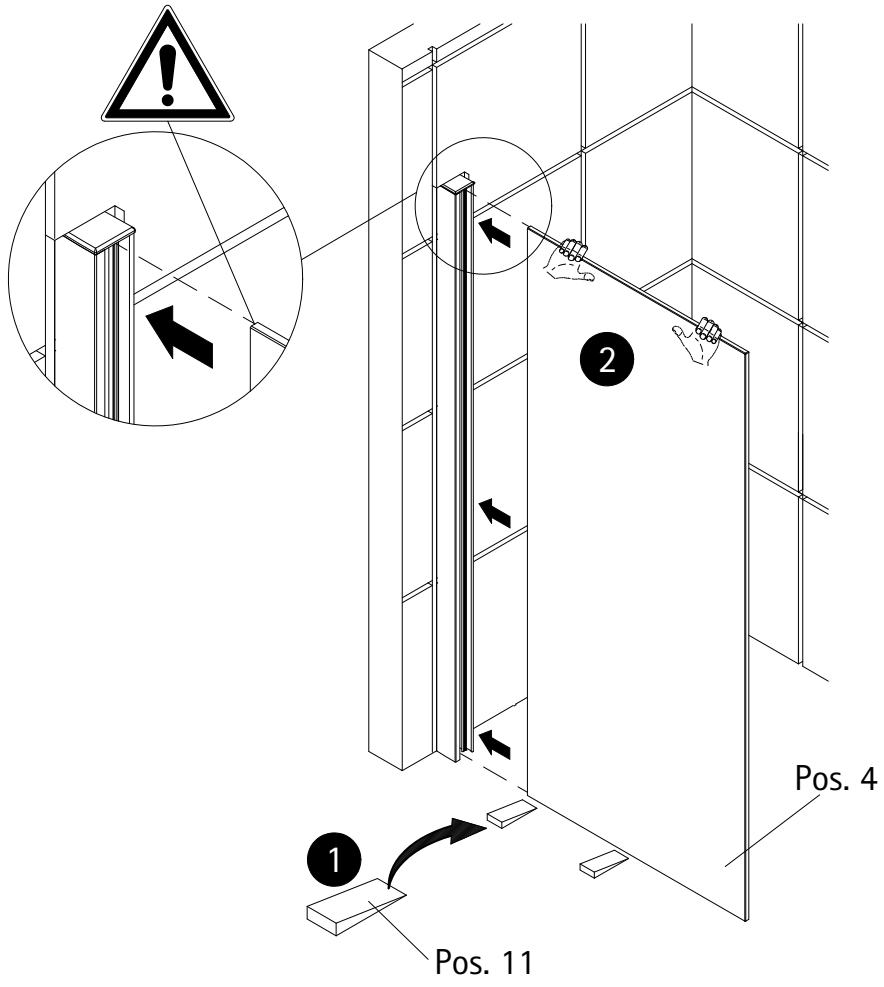

4

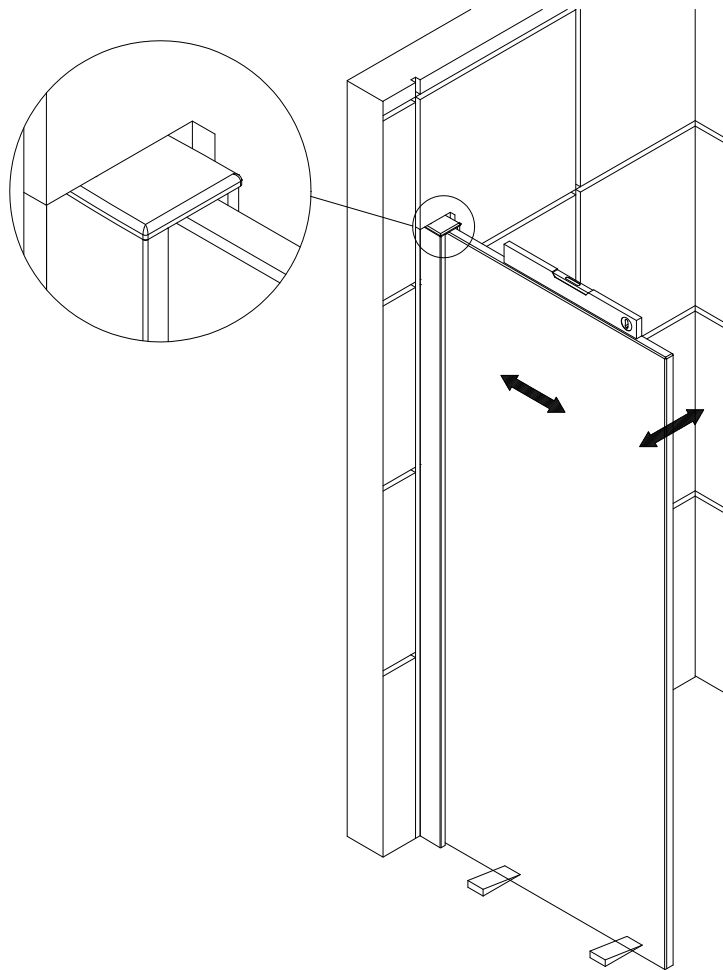

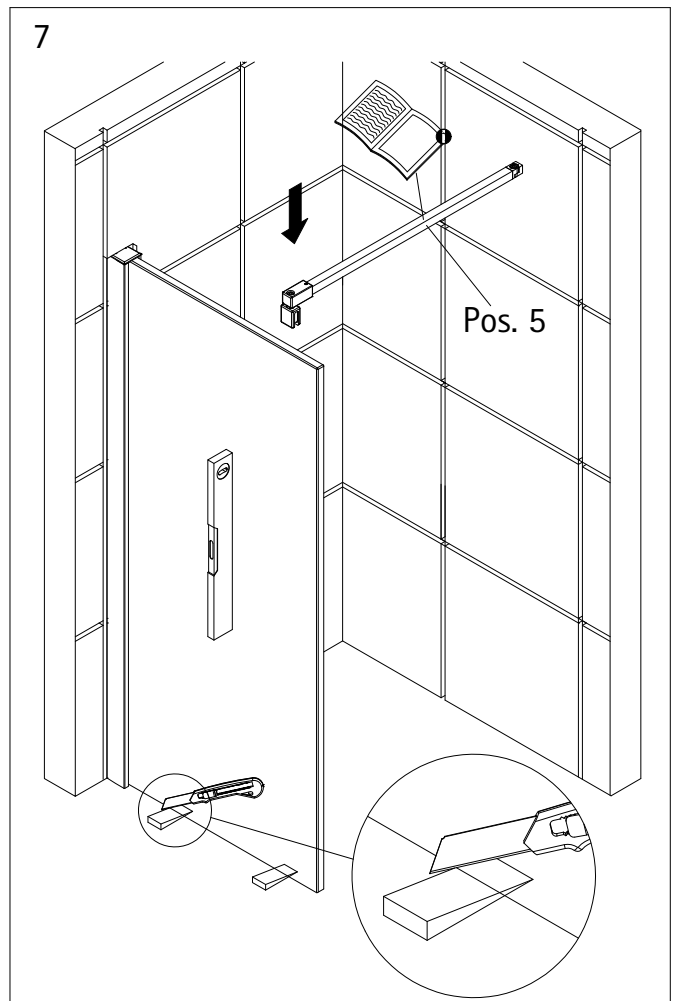
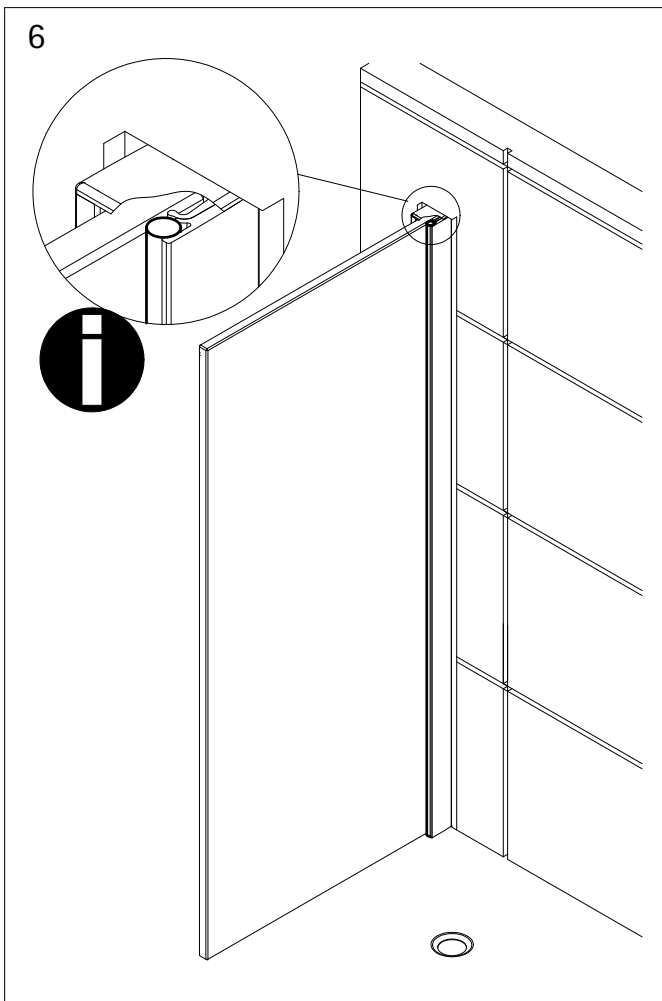
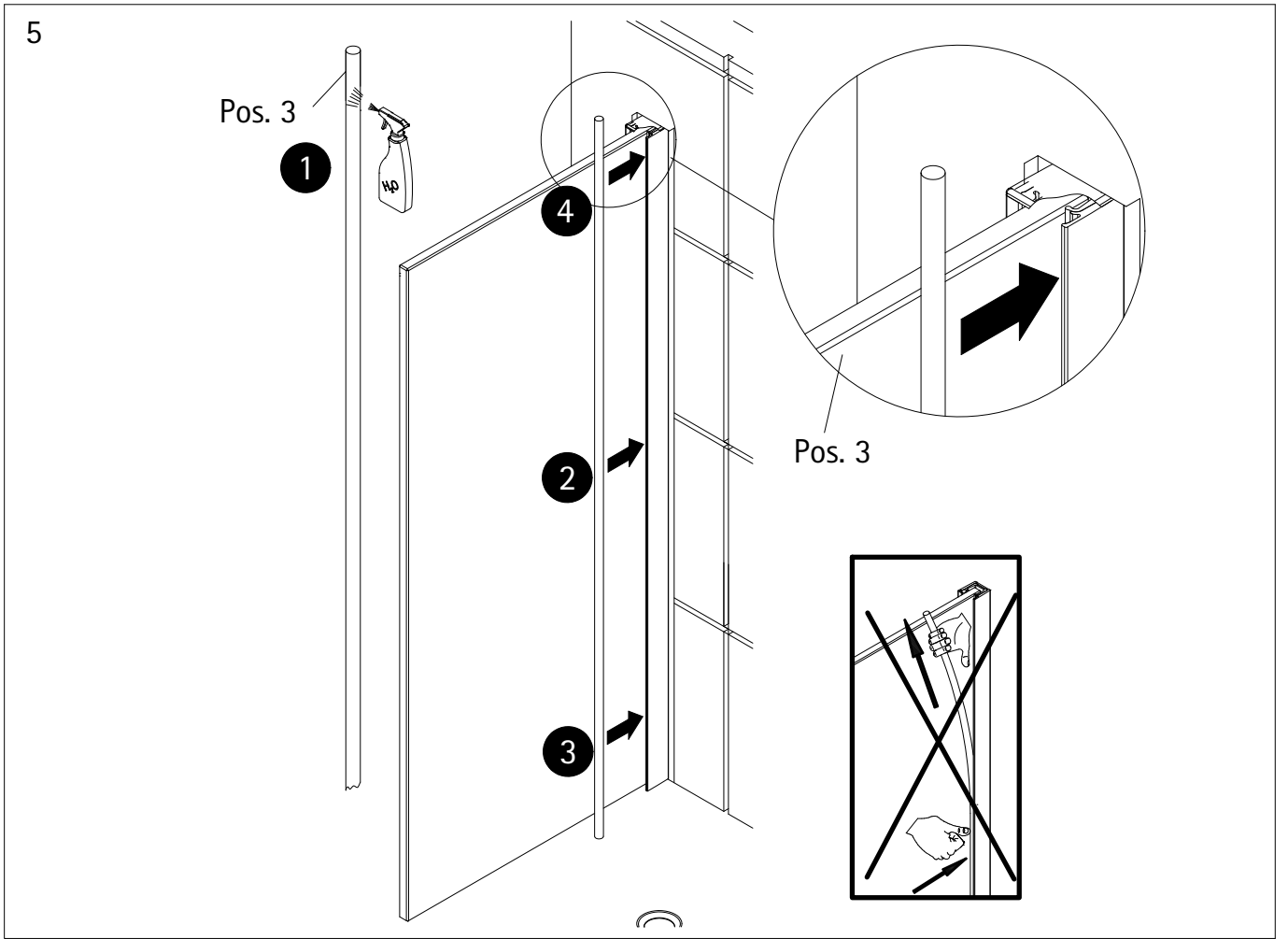

8

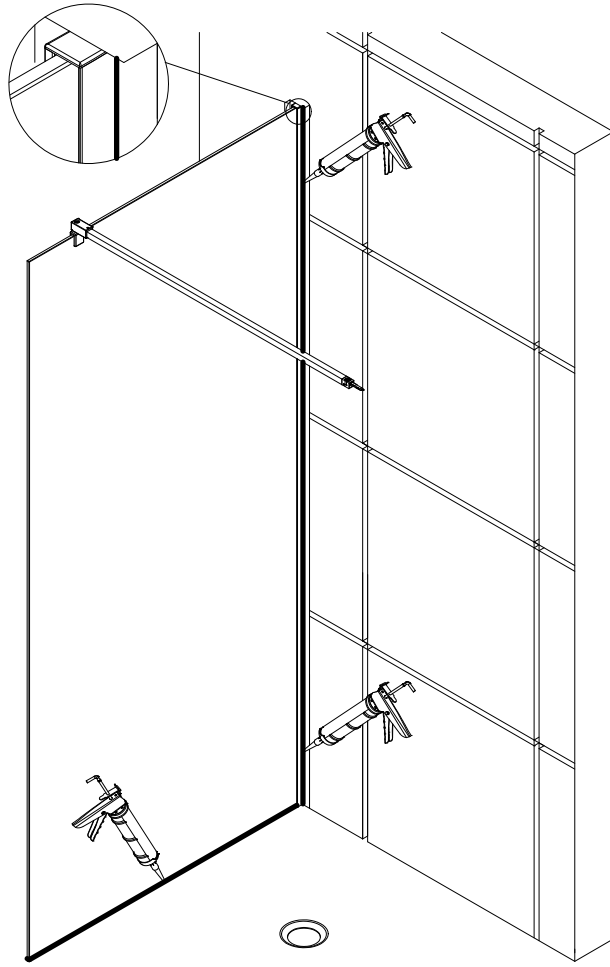

9

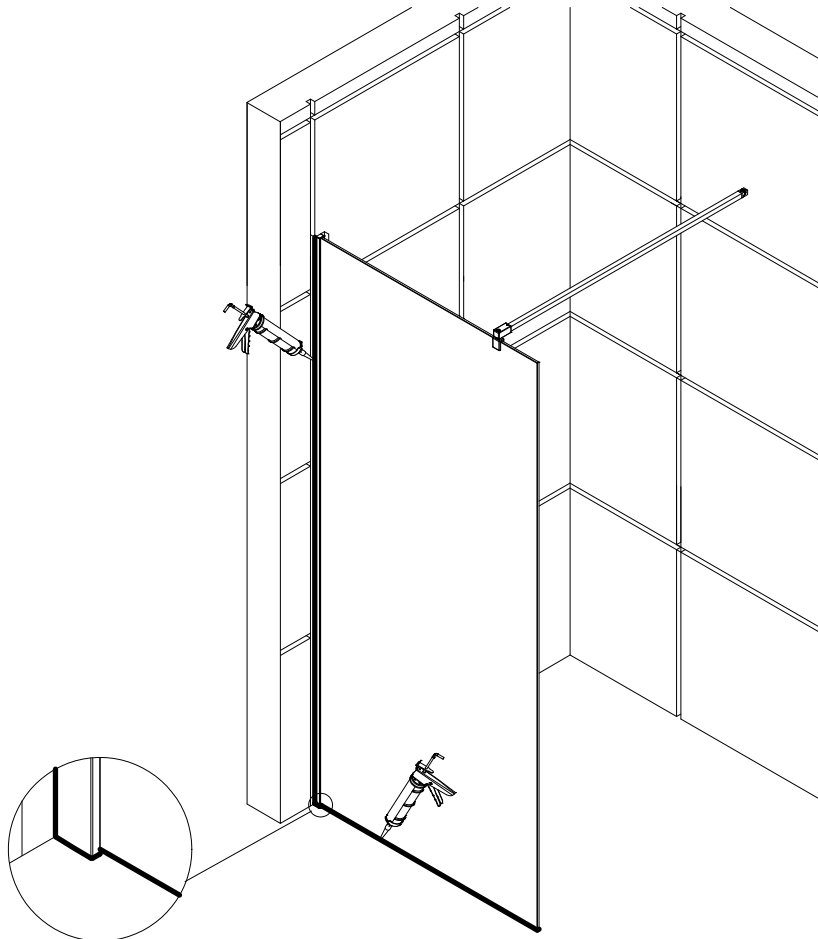

1672-6

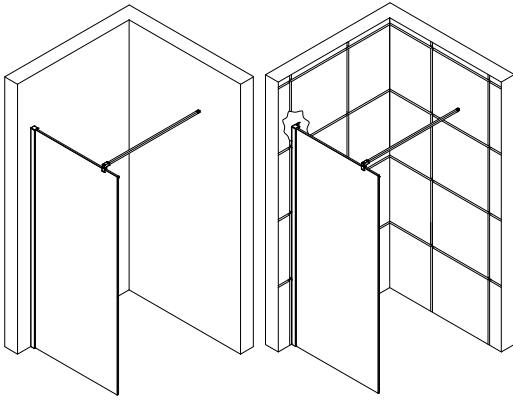

Prüfnummer / Inspection number / Numéro de contrôle / Testnummer



Ersatzteilbestellung / spare parts order
commande de pièces détachées / Bestellung van reserveonderdelen:
Fax 02962 / 972-4260



Technische Hilfe / technical help / l'aide technique / technologische ondersteuning
Telefon 02962 / 9724-0



E-Mail:
ersatzteile@duschservice.de



Duschservice
Zum Hohlen Morgen 22
59939 Olsberg
Deutschland / Germany / Allemagne / Duitsland



0000617910000000000000000000